



ENTORNO
INDUSTRIAL

 *Chemineer*  *Kenics*  *Greerco*

Mixing &

Heat Transfer

Solutions

- **Biotechnology**
- **Pharmaceutical**
- **Food Processing**
- **Cosmetics**



Meeting the Challenges of Aseptic Processes

Successful aseptic processes involve performance on many levels – from the design process through construction, validation and onto process operation. With over 5,000 installations worldwide, Chemineer has the proven experience to consistently provide validation-based products, services and system solutions.

Chemineer applies its extensive application knowledge and high quality equipment to provide the performance you require in a variety of sanitary applications including:

- Suspending, incorporating or dissolving solids with high flow/low shear impellers
- Blending fluids either in line or within process vessels
- High shear mixing, deagglomeration, dispersion and emulsification
- Maximizing heat transfer with even highly viscous or difficult to process materials

The Chemineer Difference

The extensive line of Chemineer®, Kenics® and Greerco® sanitary products coupled with Chemineer's responsive service provide numerous benefits to the

customer not often found in competitive offerings including:

- **Accelerated commissioning/validation documentation** – including product descriptions, assembly and dimensional drawings/data, surface finish data, material certifications, inspection and test reports and much more
- **Efficient order processing** – procedures specifically designed for aseptic applications to ensure timely execution and delivery
- **Application versatility** – proprietary ChemScale® method for effective product selection
- **Proven performance and extended service life** – sophisticated product design software and heavy-duty components
- **Optimal mixing efficiency** – high performance impeller options and unique flow configurations
- **Ease of maintenance** – designed for thorough clean up and simple seal maintenance to minimize downtime and costs
- **Local support** – commissioning and engineering personnel readily available to assist you



HE-3

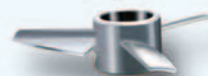

JF-3



Maxflo W



BT-6 Gas Dispersion Impeller



XE-3

Impeller Process Technology

Chemineer's impeller process technology is effectively applied across your spectrum of applications ensuring successful, repeatable results from lab scale to full scale operations.

Chemineer's mixing expertise includes low shear liquid-liquid/solids blending, gas dispersion, high shear blending and

viscous mixing. Whether you are in the R&D or production phase, from API reactors to media/buffer prep, we have the expertise to solve the latest biopharma mixing challenges.

An impeller brochure, 710, is available with additional information.

Mechanical technology must be combined with process aspects for a truly complete design. Chemineer's thorough understanding of fluid mixing dynamics is combined with current ASME-BPE concepts resulting in cleanable, robust designs.

Cleanability at the Forefront

Mixing surfaces that promote the free draining of liquids, during F.A.T. through to production operations, are vital to having the process validated. We apply this concept to all components in the mixing system including polish, welds, mounting flanges, shafts, in-tank couplings and impellers.

Mechanical Considerations

- Mixing volumes from 10–40,000+ liters including bioreactors
- Smoothline impellers
- CIP/SIP construction
- FDA or USP Class VI elastomers
- Mobile vessels: Optional right angle drives offer both low head room (14") for door-ways and low centers of gravity for tip-hazard avoidance
- Small footprint: In-line drive systems for minimum interference with nozzles and process piping
- We will engineer custom-size mixers to suit your requirements



Model DT

Model RBT

Model 20 GT

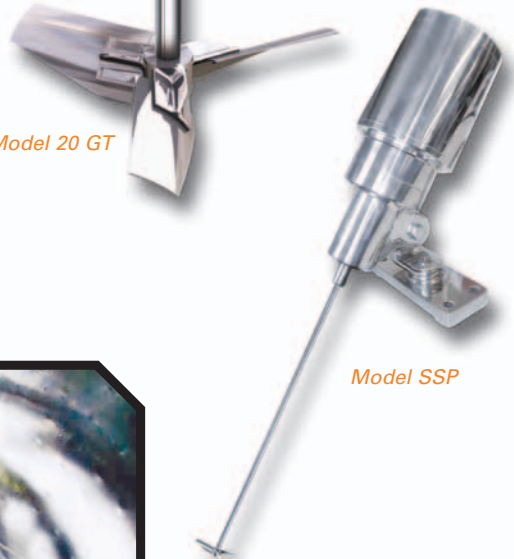

Model SSP

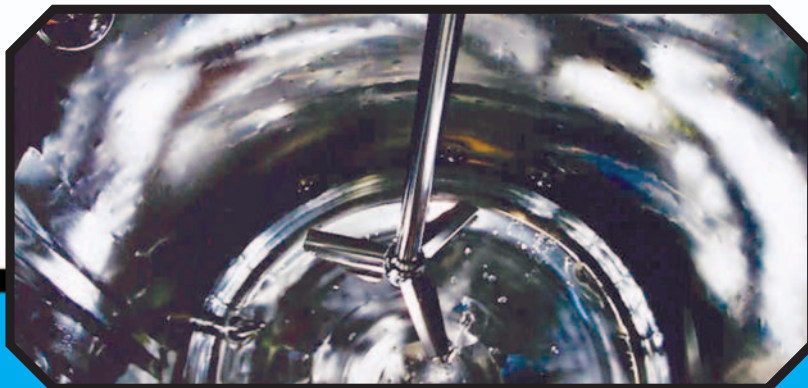

- Bottom entering designs for applications such as bioreactors
- White epoxy or all-stainless motors and gear drives – lab to full scale
- Direct drive or gear drive designs available
- Operating speed flexibility: Ask for designs below the first critical speed as they eliminate the need for programming speed avoidance ranges
- Wash down duty gear reducers: If the motor is washdown duty, make sure gear drive is as well
- Optional shaft drop collar to facilitate seal removal
- Aseptic mechanical seals
 - Dry or wet running
 - Single, double or gas lift-off designs
 - Others available upon request
- Lip seals and stuffing boxes
- Seal maintenance: Gear drive swings clear for easy access on GT's
- Sanitary in-tank couplings: Threaded or flanged connections
- Mounting flanges: ANSI, ferrule (tri-clamp), DIN, special
- Anchor nuts with washers when bolting is necessary



Sanitary, single mechanical seal assembly

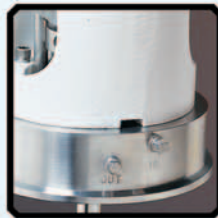

Single integral steam port in solid stainless steel mounting flange



Gear-Reduced DT Mixer

- 1 Industry standard, off-the-shelf, NEMA electric or air motor
- 2 Advanced, heat-treated gearing
- 3 Gear drive is permanently lubricated with high-performance FDA approved grease
- 4 Sealed gear drive prevents both product and lubricant contamination
- 5 Helical, AGMA quality gears provide smooth, quiet operation
- 6 Elastomeric lip seal
- 7 Heavy-duty, permanently lubricated and sealed-for-life bearings
- 8 Chuck coupling with dual set-screws or bolted flange coupling (also available), allow for shaft removal without disassembling the unit



Model SSN



Model DTN/NS

Dimensions

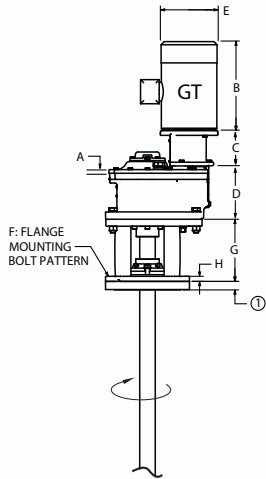
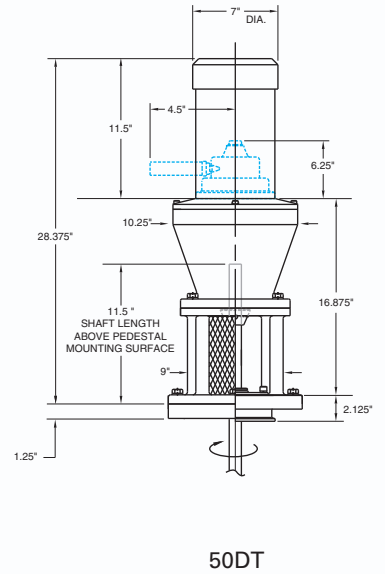
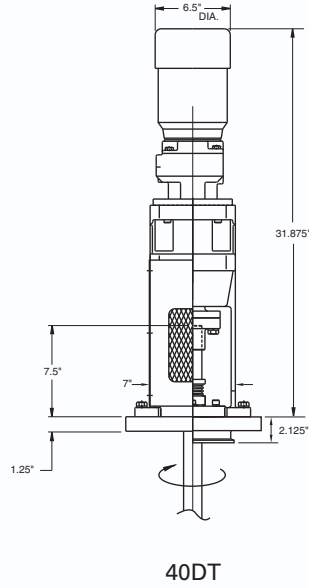
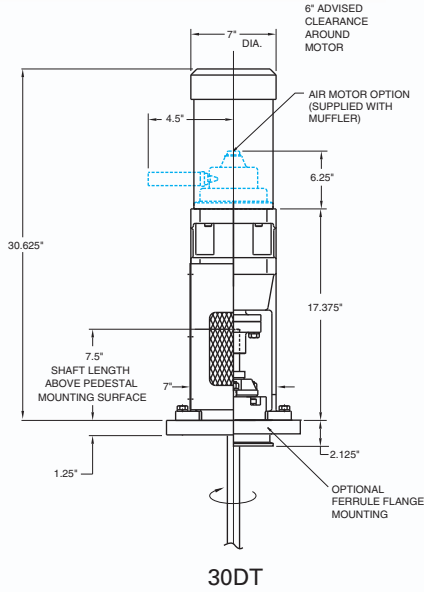

MODEL 20 GT
N, NC, NS & NT
(N, NC, & NS Drives Swivel)

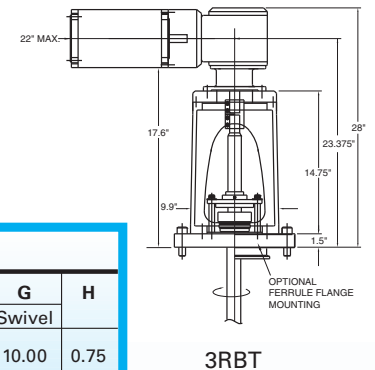
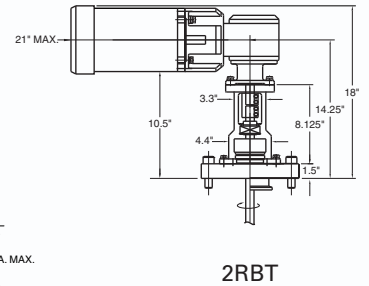
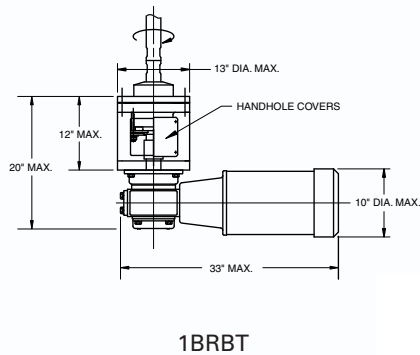

Model 20 GT Dimensions Chart

CASE SIZE	A	B (max)	C (max)	D	E (max)	F		H
						Bolt Pattern	Swivel	
21GT	1.18"	17.96"	5.51"	8.47"	11.0"	8" - 150# ANSI (Holes Straddle C.L.)	10.00	0.75
22GT	1.38"	27.0"	8.23"	10.75"	16.88"	10" - 150# ANSI (Holes on Center Line)	12.50	0.88
23GT	1.58"	31.75"	10.83"	14.80"	20.88"	12" - 150# ANSI (Holes Straddle C.L.)	14.06	1.18

1. Alternate flange sizes are available

Greerco products provide flexible, cost efficient in-line and batch processing for sanitary, high-shear applications. This technology is utilized for a wide range of deagglomeration, dispersion, emulsification and rapid mixing operations. Due to the unique and proprietary nature of the typical high shear application, this equipment is available on a rental basis for lab or full scale trials allowing customers to determine how our technology can be applied to their specific processing needs prior to purchase.

Sanitary Pipeline Mixers

Throughout the biopharm and food markets, the sanitary pipeline mixer (SPLM Series) may be applied to a wide range of intermediate and final processing operations. Like most high shear devices, the Greerco pipeline mixer employs a high-speed turbine running in close proximity to a fixed stator to perform its shearing operation. However, the Greerco product line offers a unique axial-in, axial-out flow configuration for processing benefits not seen in an axial-in, radial-out flow configuration. Product is processed as it passes through one (single) or two (tandem) of these shear zones that result in intense hydraulic and shear forces.

- 316 SS wetted parts, other materials available upon request
- Sanitary ferrule connections
- Mechanical cartridge seals
- Stainless steel base
- Washdown motor
- Discharge port with 270° rotation
- Customer specified seals and motor available



SPLM Series

Colloid Mills

The Greerco colloid mill (WV or WH Series) is a high-speed, high-shear mixer capable of batch or in-line processing. Although a “colloid mill” is commonly considered a particle destruction unit, it is actually a dispersion piece of equipment. This machine will blend, emulsify, de-agglomerate and produce a thorough wetting of dispersed substances resulting in a completely homogeneous product. Like the pipeline mixer, the colloid mill utilizes a high-speed rotor spinning in close proximity to a fixed stator. However, instead of varying the number of rotor-stator combinations to vary shear, the Greerco colloid mill offers the user the ability to adjust the gap between the rotor and stator “on-the-fly” via an external hand wheel and visible adjustment dial.

- 316 SS wetted parts, other materials available upon request
- Sanitary ferrule connections
- Jacketed stator housing
- Standard double lip seal shaft sealing (optional mechanical seal configuration)
- Horizontal (in-line) or vertical (batch) mounting
- Explosion-proof motor
- Several discharge port locations
- Options include stainless bases and white motor paint
- Customer specified seals and motors available

Tabletop colloid mill complete with hopper and recirculation tubing available for small batch and laboratory processing.



WH Series



WV Series

Kenics products include in-line static mixers and shell-and-tube heat exchangers. As the static mixing pioneer, Kenics offers its customers over thirty years experience in the design and manufacture of static mixing products.

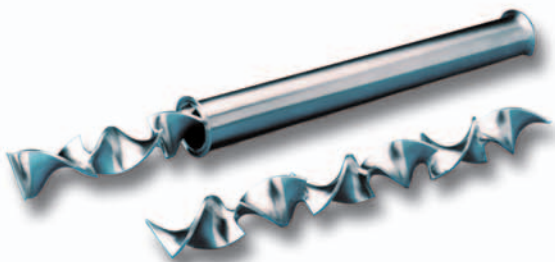

Sanitary Static Mixers

Kenics sanitary static mixers feature an alternating helical element string that creates flow division and a radial mixing mechanism to disperse and blend any fluid introduced to the mixer. Due to the plug flow characteristics of the design, this self-cleaning element design is ideal for sanitary operations. The process fluid is continuously and completely mixed within the pipeline, eliminating gradients in temperature, velocity or concentration without moving parts or any additional maintenance requirements.

- 316 LSS construction
- Sanitary ferrule connections
- Removable element assembly
- 3A certified design/construction
- Optional ASME-BPE compliant mixer and documentation
- Mirror finish on elements
- 32Ra housing finish (standard)
- 1/2" to 4" diameters in stock
- Optional electro-polishing available
- Custom housing finishes available

Sanitary Heat Exchangers

Kenics sanitary heat exchangers feature the Kenics helical element static mixers to improve the heat transfer in a sanitary shell-and-tube heat exchanger. The increased efficiency of the Kenics design offers maximum heat transfer to highly viscous, difficult-to-process materials. The plug flow design of the mixing elements increases the inside film coefficient by creating continuous surface renewal at the wall of the exchanger tubes. Benefits of the design include reduced fouling, uniform heat history and elimination of thermal gradients.

- Completely customized construction
- Removable element assemblies
- TEMA and ASME code construction
- 3A certified construction available
- Optional electro-polishing and passivation
- Sanitary ferrule connections

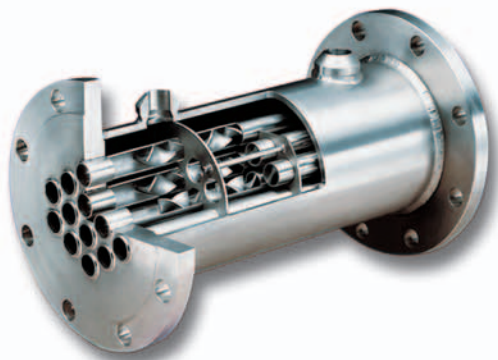

Other Quality Products from Chemineer

 *Chemineer*  *Prochem*  *Kenics*  *Greerco*



KMX-V Static Mixer

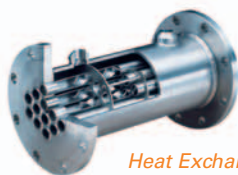

Heat Exchanger



Homogenizer



Colloid Mill



PB Agitator



Model 20 GT



KM Static Mixer



Pipeline Mixer

 *Chemineer*
 *Prochem*

Chemineer, Inc.
5870 Poe Avenue
Dayton, Ohio 45414
Telephone: (937) 454-3200
Email: chemineer@nov.com

Chemineer, Ltd.
7 Cranmer Road, West Meadows
Derby DE21 6XT, England
Telephone: 44-1-332-546700
Email: chemineeruk@nov.com

Chemineer China
Room 2005, Tower 1, Plaza Morden
369 Xianxia Road
Shanghai 200336 China
Telephone: 86-21-61240001
Email: chemineernc@nov.com

Bulletin 723

 *Kenics*
 *Greerco*

Chemineer, Inc.
125 Flagship Drive
North Andover, MA 01845
Telephone: (978) 687-0101
Email: navinfo@nov.com
www.kenics.com
www.greercomixers.com

Chemineer International Sales Offices:

Brazil
Mexico
Singapore

Your Local Contact:

ENTORNO INDUSTRIAL, S.A. DE C.V.

Juan Sarabia No. 205. Col. Nueva Santa María. 02800 México, D.F.
Tels.: (55) 5356-7206 • Fax: (55) 5356-7209
e-mail: ventas@entorno-industrial.com • direccion@entorno-industrial.com www.entorno-industrial.com

For the nearest sales office call 1-800-643-0641 or go to www.chemineer.com

National Oilwell Varco has produced this brochure for general information only, and it is not intended for design purposes. Although every effort has been made to maintain the accuracy and reliability of its contents, National Oilwell Varco in no way assumes responsibility or liability for any loss, damage or injury resulting from the use of information and data herein. All applications for the material described are at the user's risk and are the user's responsibility. All brands listed are trademarks of National Oilwell Varco.